

TRACTOR

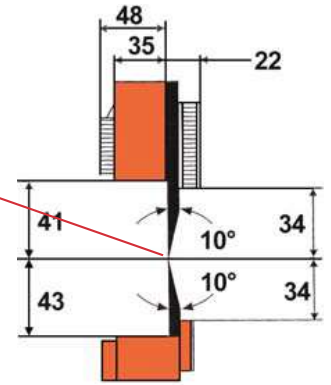

TRACTOR depaneling machine separates the prescored PCB, in a very quick and economic way. The compact and stable aluminium frame requires a minimum space. The assembled PCB panel is shoved between the circular blades and is thereby separated. The circular blades and guides are made of special steel to ensure a long time life. The hand model is suggested only for small productions.

Separation length: up to 380mm
 Thickness of panels: 0.8 ÷ 3.2mm
 Maximum components's height: 34 ÷ 43mm



- 7915.580** TRACTOR - PCB Hand depaneling machine
- 7915.582** TRACTOR - PCB Motorized depaneling machine 230V
- 7915.583** TRACTOR - PCB Motorized depaneling machine 230V/Titan blades

TRACTOR 2



TRACTOR 2M



TRACTOR 2 separates both small and large pre-scored PCBs, the maximum separation length is 450mm. The PCB is placed with its pre-scored groove onto the linear blade and the circular blade is then drawn by hand, or by motor, across the PCB. The clearance between the upper circular blade and the lower linear blade is adjustable.

	a	b	c
Min. mm	1.0	0.3	0.25
Max. mm	3.2	0.8	-

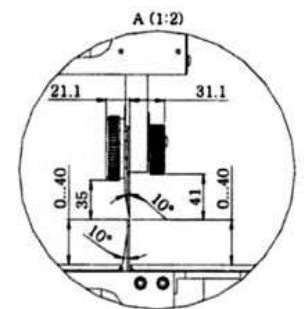
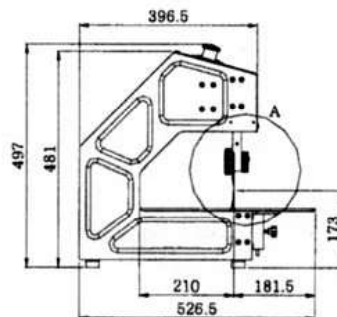
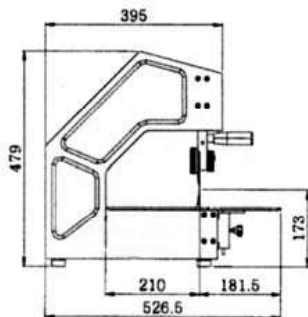
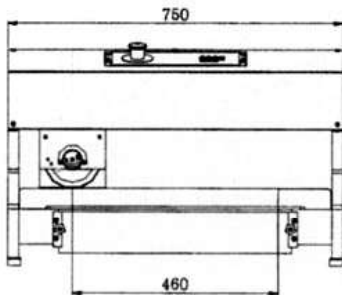
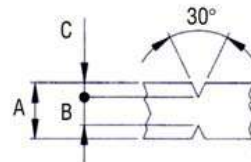

- 7915.560** TRACTOR 2 - PCB Hand depaneling machine
- 7915.564** TRACTOR 2M - PCB Motorized depaneling machine 230V

TRACTOR-MILL 2

The Tractor Mill 2 depaneling machine mills the routed tabs with the same quality of an automatic system at a lower costs. The key feature of this machine is the easy and quick change of the milling cutter and the interchangeable rail (patented).

This rail is useful to assist the operator to place and drag the circuit until the cut is complete. The particular shape of the rail avoids any damages to the assembled circuit: if the operator inserts it incorrectly it will not match the eyelet. This rail gives a total protection against possible accidents under safety rules. This manual depaneling machine has an integrated electric vacuum cleaner system therefore it's easy to place it in every working area. It has been designed and realized to solve stress problems, break or tearing out of the PCB's fibers that often occur using standard blades or manual tools and that are not tolerated with the increasing complexity and miniaturization.

TECHNICAL FEATURES:

- Aspiration: single phase turbine
- Weight: 55 Kg
- Mains Supply: 230V/50Hz
- Power: 900W
- Depression: -17 kPa (-170 mBar) / -15 kPa (-150 mBar)
- PCB thickness: Max 4mm
- Slot length (L): Min 11mm
- Slot width (V): Standard 1.0 - 3.175mm
- Slots / component distance: min. 1mm
- PCB material: FR4, CEN, (Al - with optional cutter).



- 1- Choose the right mill: 1.5 - 2.5mm
Choose the right rail



- 2- Move the PCB array towards the mill



- 3- The mill removes the PCB's tabs



7915.591 TRACTOR-MILL2 depaneling machine with pedal

MANUAL DEPANELING TOOL DP 18 ND

Manual depaneling tool designed to separate PCBs quickly, safely, and cost-effectively, ensuring clean and smooth cut surfaces. Equipped with an ESD-safe handle

TECHNICAL FEATURES:

- Maximum PCB thickness: 1.6 mm (0.070")
- Maximum cutting force: 3 kg
- Blade thickness: 1.8 mm
- Weight: 90 g - Length: 147 mm

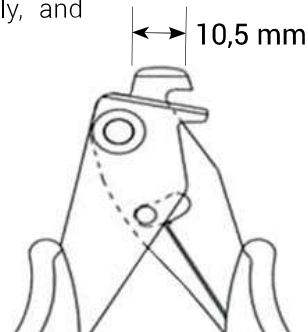

DP18ND Utensile depannellizzatore manuale

GOSMOKE

The GOSMOKE exhauster is a convenient and economical solution to the fumes associated with soft soldering. Fumes close to the worker are drawn in, filtered and direct towards the ceiling where supplementary ventilation can be eventually provided. The GOSMOKE is equipped with an axial fan and a cellular activated filter, which filters out some of the colophony, tin and lead vapours contained in the fumes. The filter should be replaced every 100 working hours.

This portable suction unit is light, space saving and quiet, by using the adjustable support the exhauster can be hung above the work table at different heights and tilted at different angles.

TECHNICAL FEATURES:

- Power: 20 W
- Air volume: 130 m³/h
- Noise: 45 dB(A)

The GOSMOKE is supplied with 4 spare filters.

7820.001



- 7820.001 Exhauster 230V (table model)
- 7820.003 Set of 4 spare filters
- 7820.004 Adjustable support for table model